

SP-560 PLUS Electronic Speed Controller

Thank you for purchasing the HITEC SP-560 PLUS electronic speed controller with reverse. This unit features competition grade performance with reversing speeds in a fully proportional mode. It can handle stock and modified class motors, with internal TEMPFET sensors to prevent overheating and damaging the unit. Additionally, the unit is polarity protected to prevent damage in the case of an accidental reversed hook-up. The SP-560 has the highest power output and best power transfer efficiency in its class.

WIRING DIAGRAM

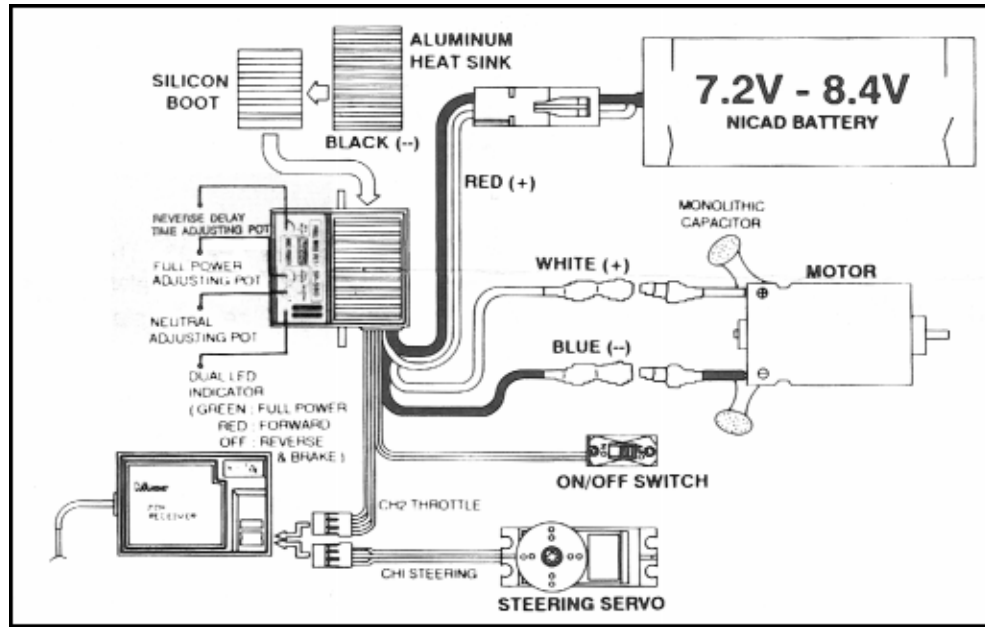

FEATURES

- MOSFETs provide high efficiency with minimum power loss.
- TEMPFET protection prevents damage due to overheating.
- Wide operating range of 6.0 to 8.4 volts with BEC. (5-7 cells)
- Light weight aluminum heatsink with new patented heat conductive silicon boot. (PAT # 4528)
- Polarity protected circuit.
- Reverse delayed time adjust system (0.1-1.0 second adjustable)

SPECIFICATIONS

	FORWARD	REVERSE
• Peak amperage capability	800A	400A
• Continuous amperage capability	200A	100A
• Voltage loss	0.007 ohm	0.014 ohm
• BEC voltage output	5.6V	
• TEMPFET cutoff point	250 degrees F (120 C)	
• Dimensions	1.77x2.16x0.78 inch (45x55x20mm)	
• Weight (with heat sink)	2.6oz (75g)	

INSTALLING THE SP-560 POWER

1. MOUNTING LUGS

Installation of the SP-560 is made easy for the car driver with the use of the servo style mounting lugs. These lugs are also removable by separating the case halves of the controller and allowing the mounting lugs to slide out.

2. CONNECTORS

If you have TAMYIA style connectors on your car, the SP-560 will be an exact match for you. However, if you choose to use different connectors for your SP-560, please see the section of these instructions which describe the wiring diagram and how to hookup the SP-560.

3. MOUNTING & CONNECTING

Mount the SP-560 into place within the chassis of your car, using the mounting lugs or double sided tape on the back of the case. Please insure that the controller is securely held in place. Once the controller is in place, disconnect the motor wires and connect the main battery wires from the car battery to the controller.

Note: Always check the polarity of the wires prior to plugging in the battery to the controller. Reversing the polarity may result in damage to the controller, despite the reverse polarity protection within the SP-560. If you do accidentally connect the controller in reverse polarity, immediately disconnect the wires and allow the controller to rest for at least one minute. Check for the correct polarity and then reconnect the main battery wires using the correct polarity. The SP-560 should now operate normally.

Once the main battery and controller are connected, turn the car radio and transmitter to the "ON" position. Check to see if the red or green indicator light on the SP-560 comes "ON" when you advance the throttle stick forward. If not, the transmitter reversing switch should be used to correct the direction. Check the operation of the steering servo for proper movement too. If the radio functions correctly, place the car on a block or car stand so that the rear wheels are not touching the ground. Connect the motor wires and be aware that the motor may begin running at this time.

4. NEUTRAL SETTING

If the motor begins running, you must set the neutral position of the controller. Make sure you set the throttle on the transmitter to neutral and the trim lever for throttle in the middle. Using the supplied tuning wand, insert the wand into the neutral adjustment hole on the SP-560 controller. Slowly turn the neutral controller potentiometer one direction or the other until the motor stops, and the red indicator light on the controller just goes out. This is the correct position for the neutral adjustment. The motor should now move the wheels in the correct direction when the red or green indicator light comes "ON" while advancing the throttle stick forward. If yes, the motor wires were cross connected. Correct it by changing the polarity of the motor wires in reverse. If no light comes "ON", correct the direction by using the reversing switch of the transmitter.

5. HIGH SPEED SETTING

To adjust the high speed setting, again disconnect the motor wires. With the motor disconnected, give the throttle on the transmitter full throttle position. You should see a green light on the SP-560 controller. If not, use the tuning wand to adjust the "FULL POWER" potentiometer until the light comes "ON" when full power is commanded from the transmitter. To take full advantage of the power band of the SP-560, adjust the full power setting so that the green light will come only when the very last bit of throttle is added to the transmitter. This will give you a broad mid-range power band which allows far better control of the car. You may now reconnect the motor to the car.

6. REVERSE DELAY TIME SETTING

The SP-560 allows you to adjust the reverse delay time from 0.1 to 1 second. Select the delay time that best fits your operating mode. Only use the plastic tuning wand supplied with the unit and always gently turn the adjusting pot to your desired setting.

TEMPFET PROTECTION

Your SP-560 controller is protected from overheating by a built in TEMPFET device. The TEMPFET is designed to prevent the controller from being damaged due to excessive heat. Some high performance modified motors and running a car in grass, mud or deep sand can cause the motor to work very hard. This causes overheating to the motor, controller and batteries. Should you overheat the SP-560, it will automatically stop the car until the controller cools down. If you should experience this, you should take the time to find the cause of the car working so hard. This could be dragging parts, jammed wheels, too tight of a gear mesh, and broken parts. Always check the car carefully before continuing to run the car. The SP-560 will return to normal operation in a few minutes.

ALUMINUM HEAT SINK AND SILICON BOOT

In any case where high speed running is done, rough terrain is encountered, or high powered motors are used, always place the aluminum heatsink on the controller to assist in cooling the controller. The SP-560 will be more efficient when it runs cooler. Also, the SP-560 has a silicon heatsink boot which not only helps the heatsink to attach to the controller, but it also transfers the heat away from the controller and keeps the MOSFETs separated. Please leave the silicon boot in place at all times.

ADDITIONAL TIPS

1. MONOLITHIC CAPACITORS

Motors on model cars generate static electricity which interfere with radio control equipment. To prevent this from happening, it is necessary to place at least two (2) monolithic capacitors to the motor of the car. These are supplied with the SP-560. Solder one end of a capacitor to the positive (+) pole of the motor endbell and the other end to metal casing of the motor. With the second capacitor, solder one end to the negative (-) pole of the motor endbell to the same place on the casing as the first capacitor.

2. AIR CIRCULATION

You can expect some heat to be felt by the heatsink of the SP-560. This is quite normal. Because the SP-560 operates more efficient when it is cool, always place the controller on the car chassis in a position where it will receive plenty of air circulation.

3. POWER LOSS PROTECTION

Although the connectors on the SP-560 are already mounted to the 15 gauge wires, we recommend that you keep the wires as short as possible to get best results. If you are capable of soldering these wires, the best connection possible will be to connect the motor wires directly to the motor, leaving the bullet style motor wire connectors off completely.

ALTERNATE WIRING AND WIRING DIAGRAM

The SP-560 can be adapted for use with other wire connectors. If you find that you must change the connectors, please study the wiring diagram carefully. The red wire is for battery positive (+), the black is battery negative (-), white is motor positive (+) and blue is motor negative (-). The receiver connector is suitable for use with FUTABA, JR PROPO, and HITEC systems. When changing connectors, always use a high grade rosin core solder only, and insulate all connections with heat shrink tubing. Now, go hit the track and good racing!

The logo for HITEC, featuring the word "hitec" in a bold, lowercase, sans-serif font. The letters are black with a white outline, giving it a three-dimensional appearance.